

8 7 6 5 4 3 2 1

REV	DESCRIPTION	BY	DATE	APPD
00	INITIAL RELEASE	GSC	2020/4/28	HH

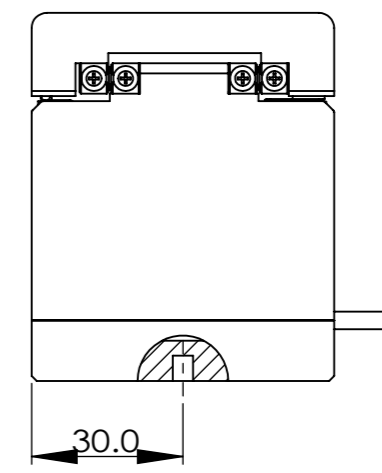
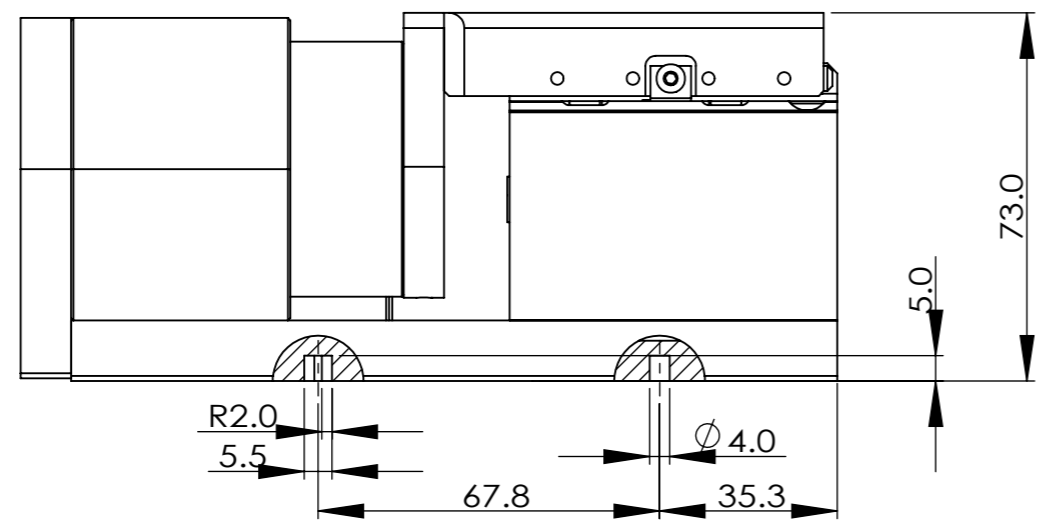
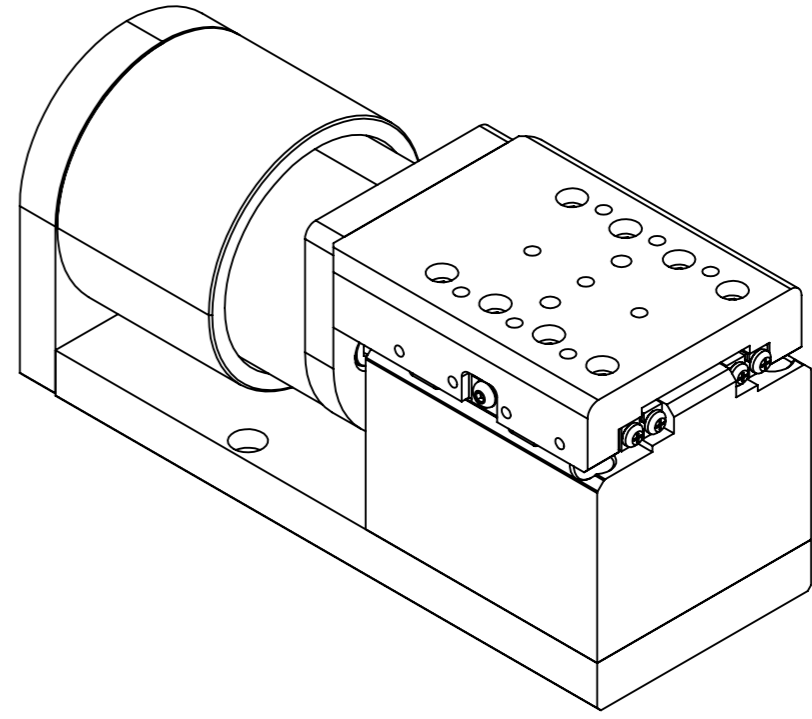
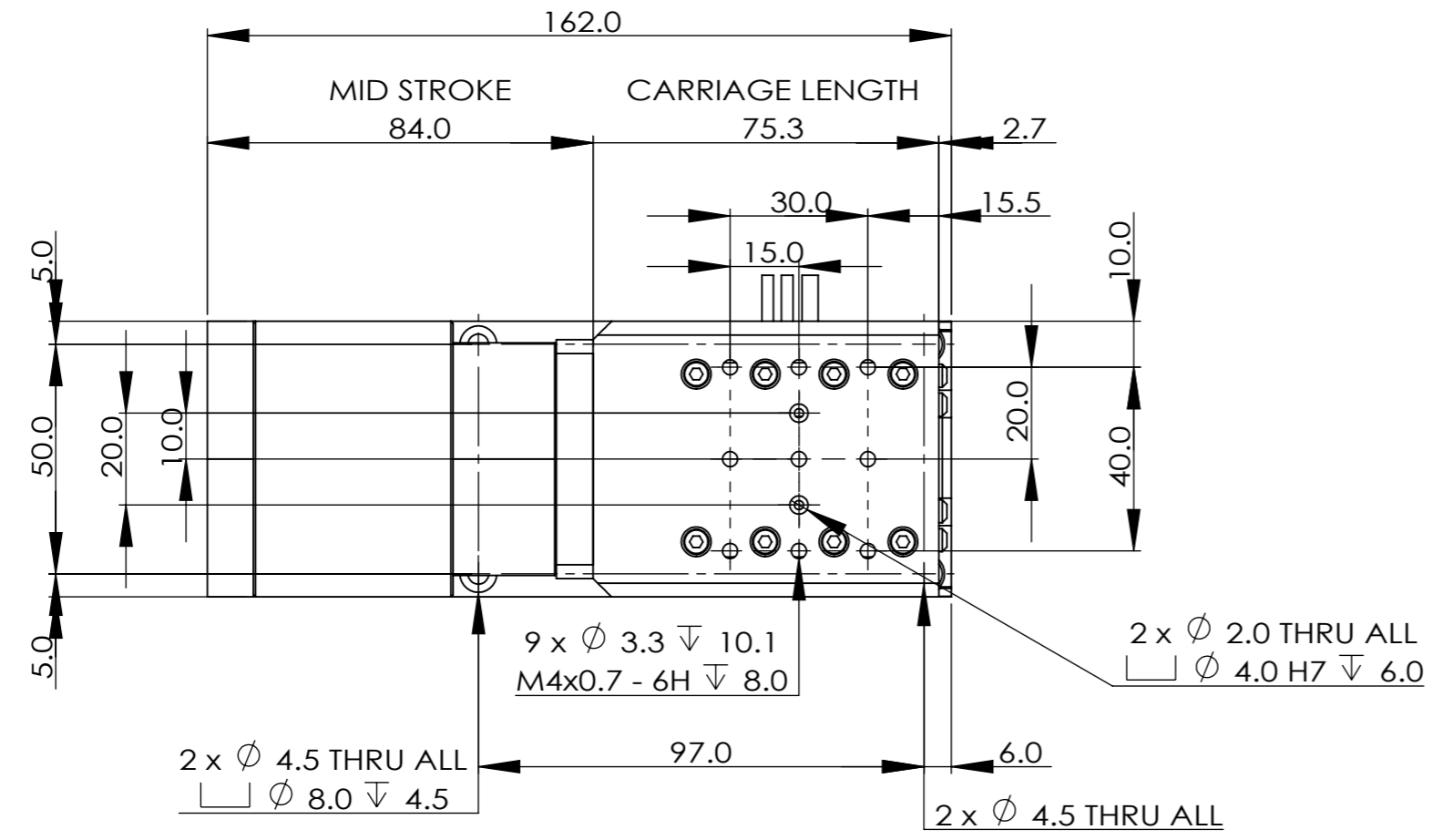

RELEASED DATE:
2024/4/25

<p>AKRIBIS SYSTEMS CONFIDENTIAL: THIS DOCUMENT AND THE INFORMATION CONTAINED IN IT ARE CONFIDENTIAL, AND CANNOT BE COPIED OR DISCLOSED IN WHOLE OR IN PART WITHOUT WRITTEN CONSENT OF AKRIBIS SYS PTE LTD</p>	<p>UNLESS OTHERWISE SPECIFIED, ALL DIMENSIONS IN mm REMOVE ALL SHARP EDGES</p>	Designed	GSC	2020/4/28	 <p>Akribis Systems Pte Ltd ©2004. All rights reserved.</p>
		Drawn	GSC	2020/4/28	
		Checked	QBA	2024/4/25	
		Approved	QBA	2024/4/25	
		Material	NA		
		Surface Treatment	NA		
Heat Treatment	NA		Model: NA		
Quantity	NA		Title : XMGV60-25		
			Dwg No:		
			Sheet: 1 OF 1		
			Rev: 00		

8 7 6 5 4 3 2 1