

Performance Parameters	Symbol	Unit	AVM80-12
Stroke	S	mm	12.0
Continuous Force @100°C ^{[1][2]}	F _c	N	47.9
Peak Force ^[2]	F _{pk}	N	205.9
Force Constant ±10% ^[2]	K _f	N/A	32.8
Back EMF Constant ±10% ^[2]	K _e	V/(m/s)	32.8
Motor Constant @25°C ^[2]	K _m	N/Sqrt(W)	12.0
Resistance @25°C ±10% ^[3]	R ₂₅	Ω	7.50
Inductance ±20% ^[4]	L	mH	4.10
Electrical Time Constant	τ _e	ms	0.55
Continuous Current @100°C ^[1]	I _c	A	1.5
Peak Current	I _{pk}	A	6.2
Continuous Power Dissipation @100°C ^[1]	P _c	W	20.6
Max. Coil Temperature	t _{max}	°C	100
Thermal Dissipation Constant ^[1]	K _{th}	W/°C	0.275
Max. Voltage	U _{max}	Vdc	60
Coil Mass	m _{coil}	g	235.3
Core Mass	m _{core}	g	1265.0
Running Clearance	L _{gap}	mm	0.60

[1] Measurement is taken at ambient temperature 25°C. Value depends on the thermal environment.

[2] The values are at mid stroke.

[3] Resistance is measured by DC current with 0.5 m lead wire.

[4] Inductance is measured by current frequency of 1 kHz.

The contents of datasheet are subject to change without prior notice.

AVM80-12

REV	DESCRIPTION	BY	DATE	APPD
0	INITIAL RELEASE	WSM	2021/10/26	YX
1	Inductance Value Correction	WQY	2025/01/20	YX

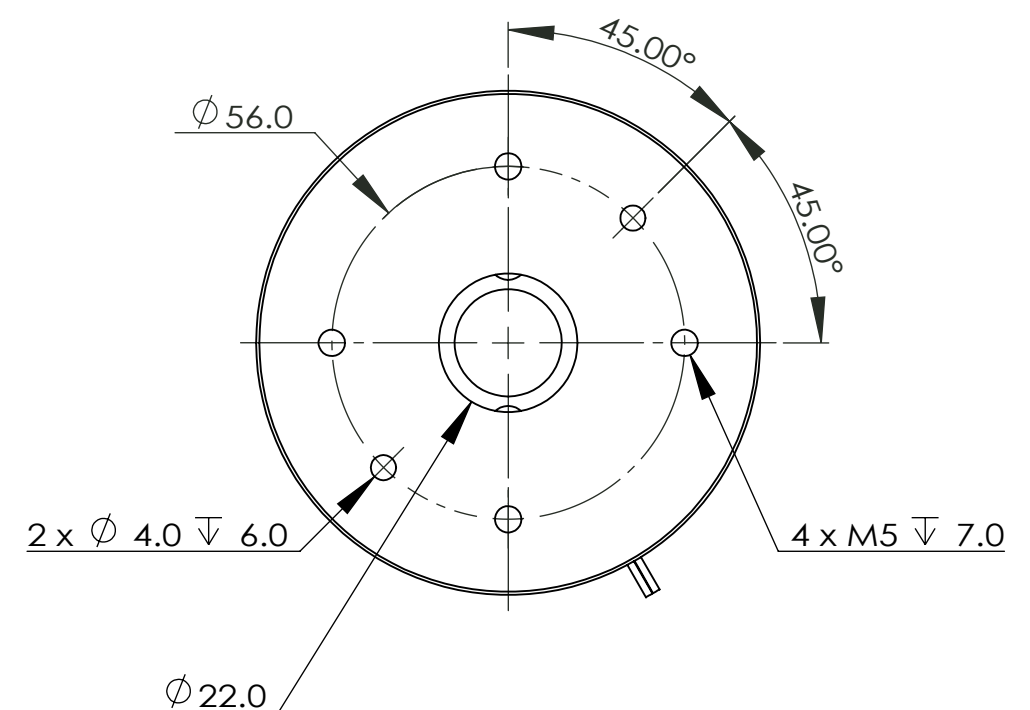
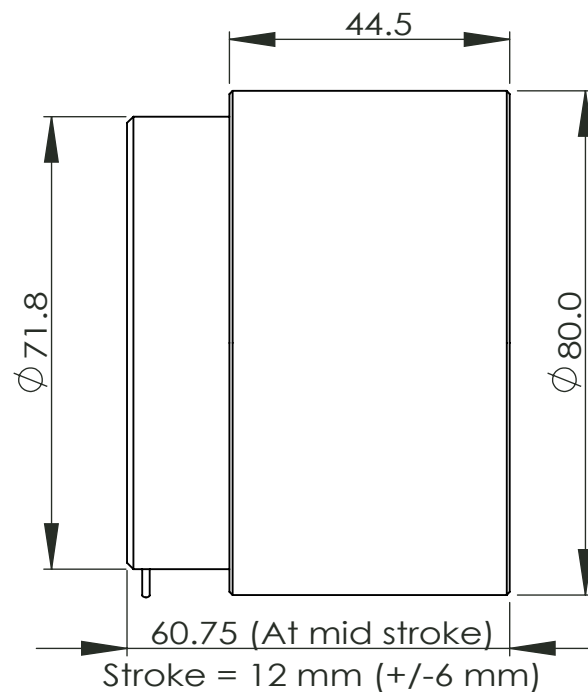
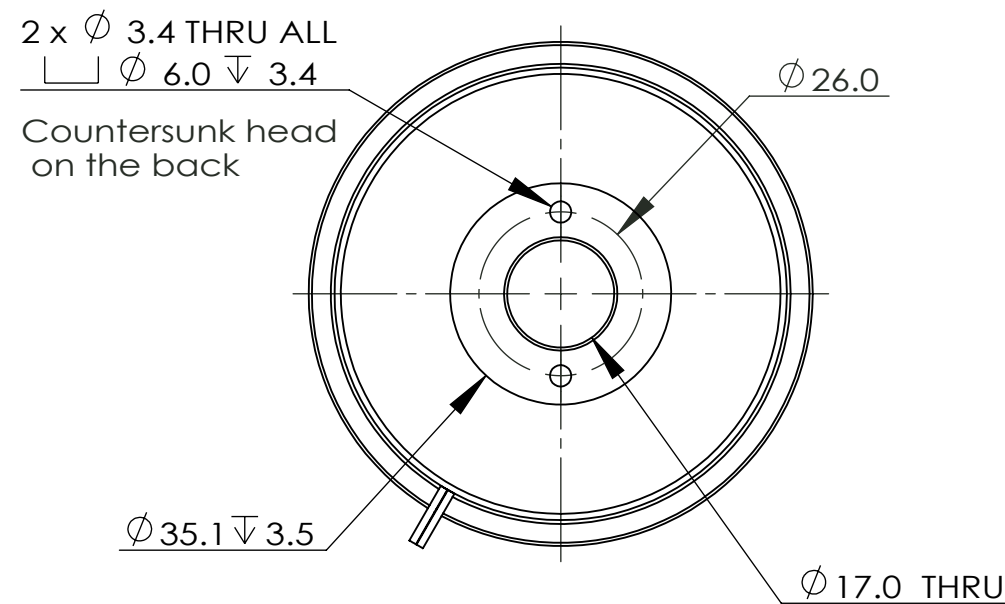
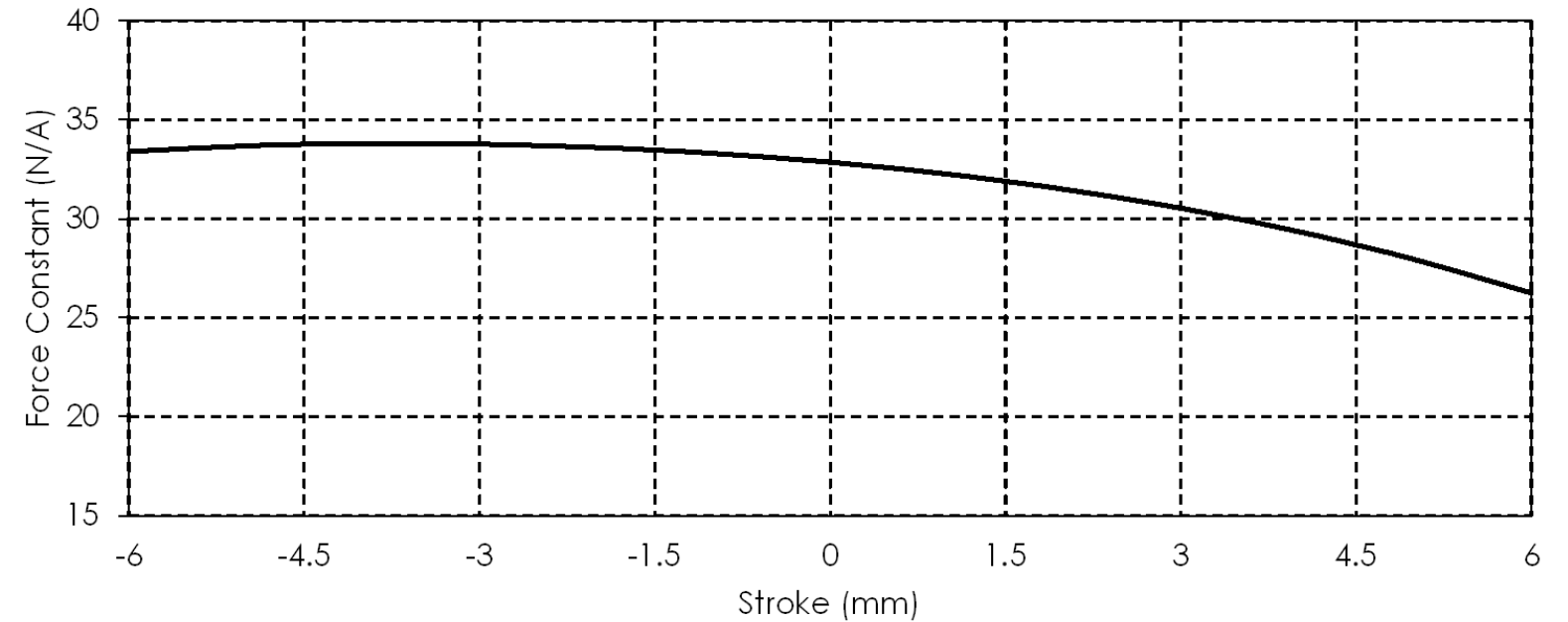

AKRIBIS SYSTEMS
 CONFIDENTIAL:
 THIS DOCUMENT AND
 THE INFORMATION
 CONTAINED IN IT ARE
 CONFIDENTIAL, AND
 CANNOT BE COPIED OR
 DISCLOSED IN WHOLE
 OR IN PART WITHOUT
 WRITTEN CONSENT OF
 AKRIBIS SYS PTE LTD

UNLESS OTHERWISE SPECIFIED,
 ALL DIMENSIONS IN mm
 REMOVE ALL SHARP EDGES

GENERAL
 TOLERANCE
 X ± 0.25mm
 X.X ± 0.1mm
 X.XX ± 0.05mm
 X.XXX ± 0.025mm



Designed	SL	2021/10/25
Drawn	WSM	2021/10/25
Checked	YH	2021/10/26
Approved	YX	2021/10/26
Material	NA	
Surface Treatment	NA	
Heat Treatment	NA	
Quantity	NA	



Akribis
 Systems Pte Ltd
 ©2004. All rights reserved.

Model:	AVM80-12_Customer Drawing
Title:	AVM80-12_Customer Drawing
Dwg No:	AVM80-12
Sheet:	1 OF 1
Rev:	0