

| Performance Parameters                             | Symbol            | Unit      | AVM75-HF-25 |
|--|-------------------|-----------|-------------|
| Stroke   | S                 | mm        | 25.0        |
| Continuous Force @100°C <sup>[1][2]</sup>          | F <sub>c</sub>    | N         | 127.9       |
| Peak Force <sup>[2]</sup>                          | F <sub>pk</sub>   | N         | 590.1       |
| Force Constant ±10% <sup>[2]</sup>                 | K <sub>f</sub>    | N/A       | 34.6        |
| Back EMF Constant ±10% <sup>[2]</sup>              | K <sub>e</sub>    | V/(m/s)   | 34.6        |
| Motor Constant @25°C <sup>[2]</sup>                | K <sub>m</sub>    | N/Sqrt(W) | 20.6        |
| Resistance @25°C ±10% <sup>[3]</sup>               | R <sub>25</sub>   | Ω         | 2.83        |
| Inductance ±20% <sup>[4]</sup>                     | L                 | mH        | 2.76        |
| Electrical Time Constant                           | T <sub>e</sub>    | ms        | 0.98        |
| Continuous Current @100°C <sup>[1]</sup>           | I <sub>c</sub>    | A         | 3.7         |
| Peak Current                                       | I <sub>pk</sub>   | A         | 17.0        |
| Continuous Power Dissipation @100°C <sup>[1]</sup> | P <sub>c</sub>    | W         | 49.8        |
| Max. Coil Temperature                              | t <sub>max</sub>  | °C        | 100         |
| Thermal Dissipation Constant <sup>[1]</sup>        | K <sub>th</sub>   | W/°C      | 0.665       |
| Max. Voltage                                       | U <sub>max</sub>  | Vdc       | 60          |
| Coil Mass  | m <sub>coil</sub> | g         | 710.0       |
| Core Mass  | m <sub>core</sub> | g         | 1940.0      |
| Running Clearance                                  | L <sub>gap</sub>  | mm        | 0.50        |

[1] Measurement is taken at ambient temperature 25°C. Value depends on the thermal environment.

[2] The values are at mid stroke.

[3] Resistance is measured by DC current with 0.5 m lead wire.

[4] Inductance is measured by current frequency of 1 kHz.

The contents of datasheet are subject to change without prior notice.

# AVM75-HF-25

| REV | DESCRIPTION     | BY  | DATE       | APPD |
|-----|-----------------|-----|------------|------|
| 0   | INITIAL RELEASE | WSM | 2021/10/26 | YX   |

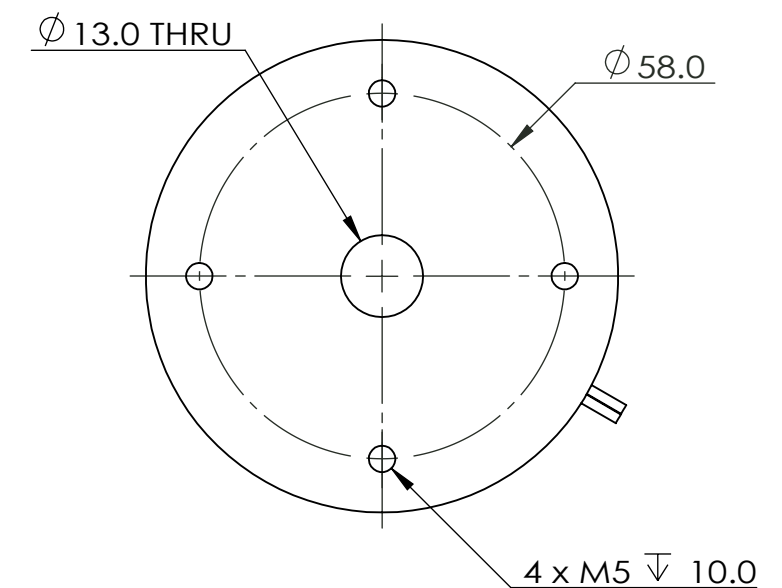
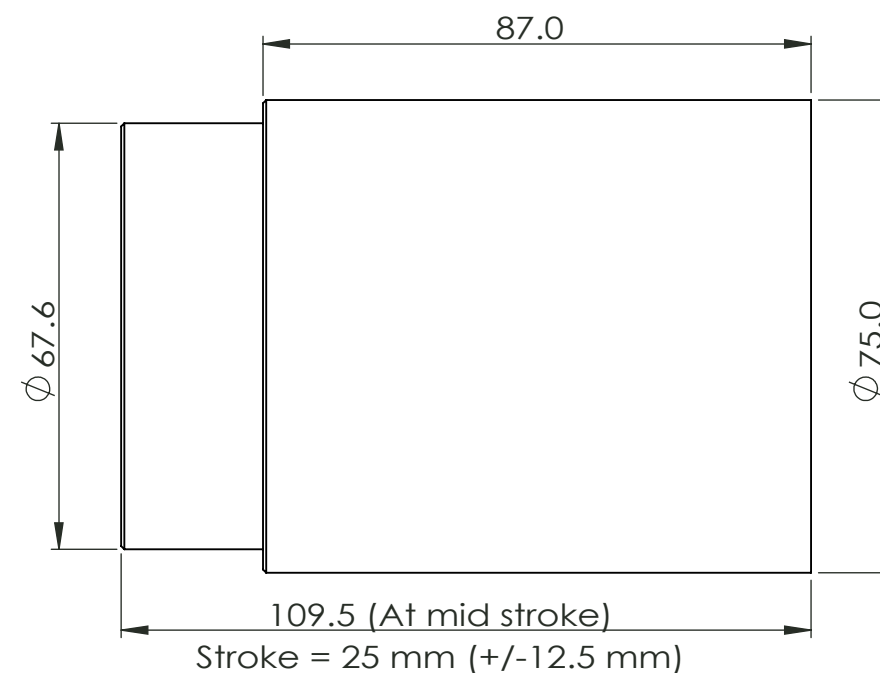
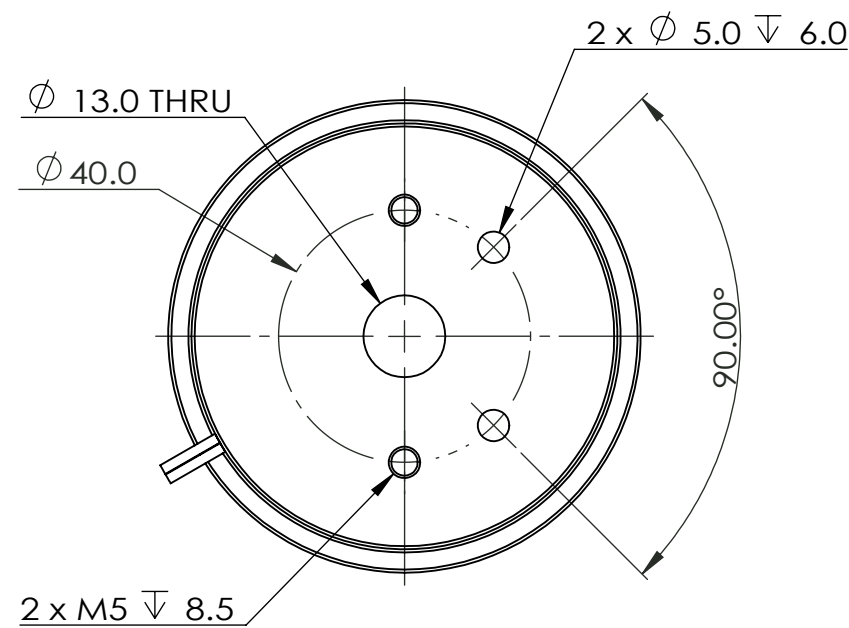
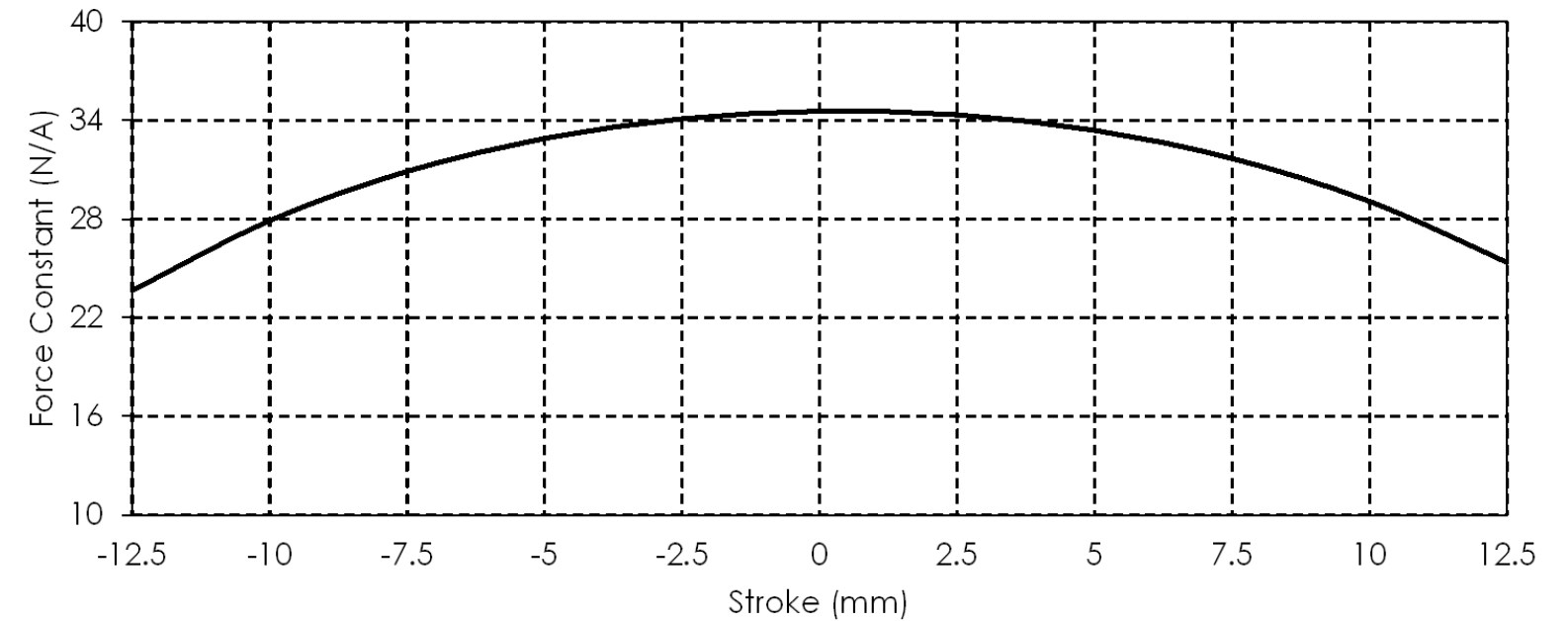

AKRIBIS SYSTEMS  
CONFIDENTIAL:  
THIS DOCUMENT AND  
THE INFORMATION  
CONTAINED IN IT ARE  
CONFIDENTIAL, AND  
CANNOT BE COPIED OR  
DISCLOSED IN WHOLE  
OR IN PART WITHOUT  
WRITTEN CONSENT OF  
AKRIBIS SYS PTE LTD

UNLESS OTHERWISE SPECIFIED,  
ALL DIMENSIONS IN mm  
REMOVE ALL SHARP EDGES

GENERAL  
TOLERANCE  
X ± 0.25mm  
X.X ± 0.1mm  
X.XX ± 0.05mm  
X.XXX ± 0.025mm



|                   |     |            |
|-------------------|-----|------------|
| Designed          | SL  | 2021/10/25 |
| Drawn             | WSM | 2021/10/25 |
| Checked           | YH  | 2021/10/26 |
| Approved          | YX  | 2021/10/26 |
| Material          | NA  |            |
| Surface Treatment | NA  |            |
| Heat Treatment    | NA  |            |
| Quantity          | NA  |            |

**Akribis**  
Systems Pte Ltd  
©2004. All rights reserved.

|         |                              |
|---------|------------------------------|
| Model:  | AVM75-HF-25_Customer Drawing |
| Title:  | AVM75-HF-25_Customer Drawing |
| Dwg No: | AVM75-HF-25                  |
| Sheet:  | 1 OF 1                       |
| Rev:    | 0                            |