

Performance Parameters	Symbol	Unit	AVM24-HF-10
Stroke	S	mm	10.0
Continuous Force @100°C <sup>[1][2]</sup>	F <sub>c</sub>	N	7.53
Peak Force <sup>[2]</sup>	F <sub>pk</sub>	N	40.9
Force Constant ±10% <sup>[2]</sup>	K <sub>f</sub>	N/A	10.8
Back EMF Constant ±10% <sup>[2]</sup>	K <sub>e</sub>	V/(m/s)	10.8
Motor Constant @25°C <sup>[2]</sup>	K <sub>m</sub>	N/Sqrt(W)	3.45
Resistance @25°C ±10% <sup>[3]</sup>	R <sub>25</sub>	Ω	9.70
Inductance ±20% <sup>[4]</sup>	L	mH	2.11
Electrical Time Constant	T <sub>e</sub>	ms	0.22
Continuous Current @100°C <sup>[1]</sup>	I <sub>c</sub>	A	0.7
Peak Current	I <sub>pk</sub>	A	3.8
Continuous Power Dissipation @100°C <sup>[1]</sup>	P <sub>c</sub>	W	6.1
Max. Coil Temperature	t <sub>max</sub>	°C	100
Thermal Dissipation Constant <sup>[1]</sup>	K <sub>th</sub>	W/°C	0.082
Max. Voltage	U <sub>max</sub>	Vdc	60
Coil Mass	m <sub>coil</sub>	g	28.6
Core Mass	m <sub>core</sub>	g	81.1
Running Clearance	L <sub>gap</sub>	mm	0.50

[1] Measurement is taken at ambient temperature 25°C. Value depends on the thermal environment.

[2] The values are at mid stroke.

[3] Resistance is measured by DC current with 0.5 m lead wire.

[4] Inductance is measured by current frequency of 1 kHz.

The contents of datasheet are subject to change without prior notice.

# AVM24-HF-10

REV	DESCRIPTION	BY	DATE	APPD
0	INITIAL RELEASE	SL	2021/10/26	YX

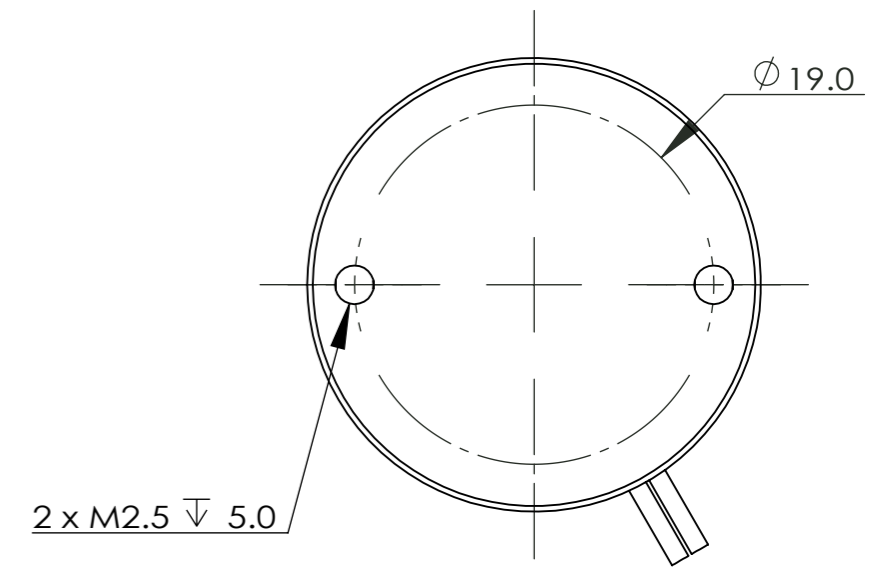
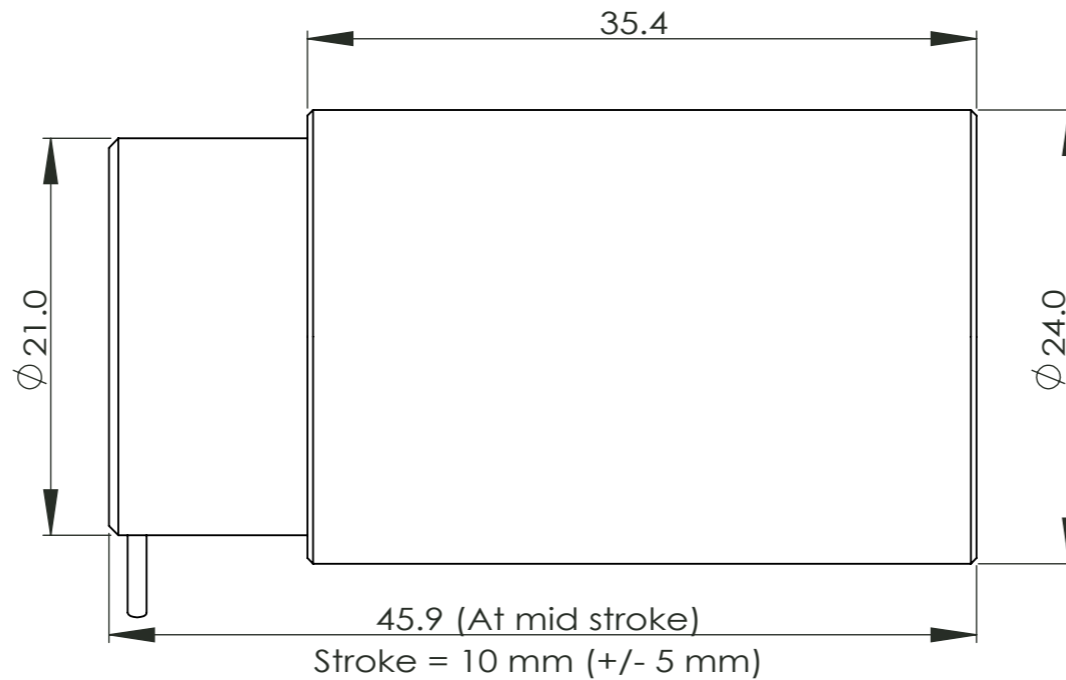
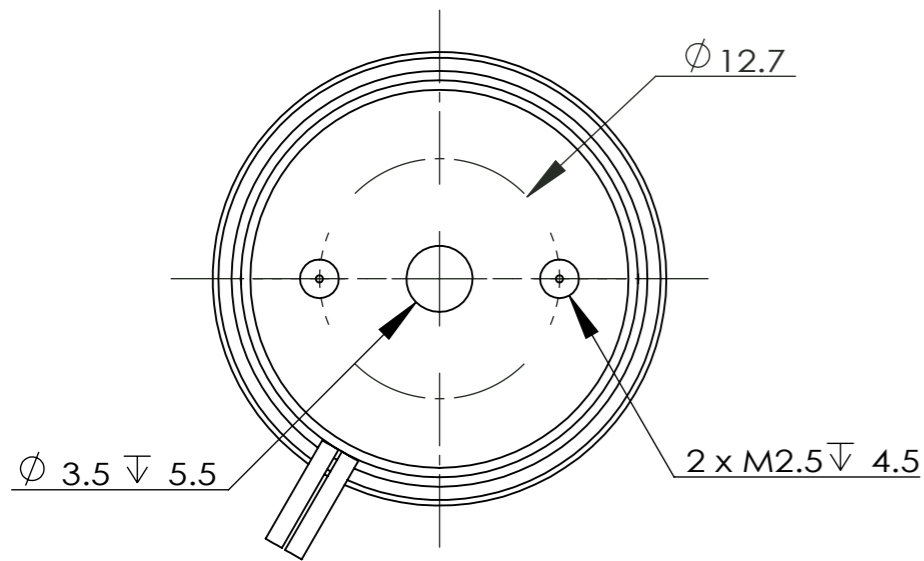
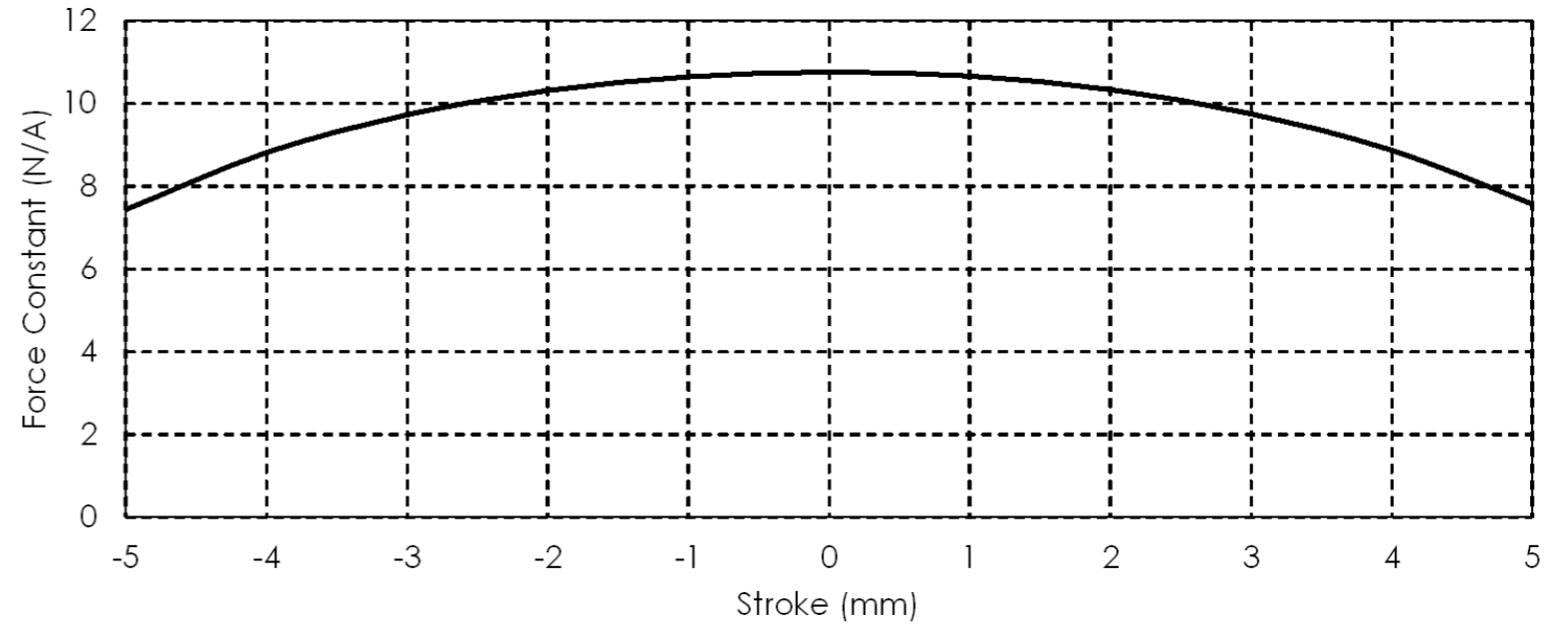

AKRIBIS SYSTEMS  
CONFIDENTIAL:  
THIS DOCUMENT AND  
THE INFORMATION  
CONTAINED IN IT ARE  
CONFIDENTIAL, AND  
CANNOT BE COPIED OR  
DISCLOSED IN WHOLE  
OR IN PART WITHOUT  
WRITTEN CONSENT OF  
AKRIBIS SYS PTE LTD

UNLESS OTHERWISE SPECIFIED,  
ALL DIMENSIONS IN mm  
REMOVE ALL SHARP EDGES

GENERAL  
TOLERANCE  
X ± 0.25mm  
X.X ± 0.1mm  
X.XX ± 0.05mm  
X.XXX ± 0.025mm



Designed	SL	2021/10/25
Drawn	SL	2021/10/25
Checked	YH	2021/10/26
Approved	YX	2021/10/26
Material	NA	
Surface Treatment	NA	
Heat Treatment	NA	
Quantity	NA	

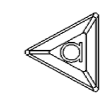

**Akribis**  
Systems Pte Ltd  
©2004. All rights reserved.

Model:	AVM24-HF-10_Customer Drawing
Title:	AVM24-HF-10_Customer Drawing
Dwg No:	AVM24-HF-10
Sheet:	1 OF 1
Rev:	0