

Performance Parameters	Symbol	Unit	AVM20-HF-6
Stroke	S	mm	6.0
Continuous Force @100°C ^{[1][2]}	F _c	N	5.44
Peak Force ^[2]	F _{pk}	N	16.3
Force Constant ±10% ^[2]	K _f	N/A	4.54
Back EMF Constant ±10% ^[2]	K _e	V/(m/s)	4.54
Motor Constant @25°C ^[2]	K _m	N/Sqrt(W)	2.06
Resistance @25°C ±10% ^[3]	R ₂₅	Ω	4.84
Inductance ±20% ^[4]	L	mH	0.60
Electrical Time Constant	T _e	ms	0.12
Continuous Current @100°C ^[1]	I _c	A	1.2
Peak Current	I _{pk}	A	3.6
Continuous Power Dissipation @100°C ^[1]	P _c	W	9.0
Max. Coil Temperature	t _{max}	°C	100
Thermal Dissipation Constant ^[1]	K _{th}	W/°C	0.120
Max. Voltage	U _{max}	Vdc	60
Coil Mass	m _{coil}	g	13.5
Core Mass	m _{core}	g	47.5
Running Clearance	L _{gap}	mm	0.50

[1] Measurement is taken at ambient temperature 25°C. Value depends on the thermal environment.

[2] The values are at mid stroke.

[3] Resistance is measured by DC current with 0.5 m lead wire.

[4] Inductance is measured by current frequency of 1 kHz.

The contents of datasheet are subject to change without prior notice.

AVM20-HF-6

REV	DESCRIPTION	BY	DATE	APPD
0	INITIAL RELEASE	WSM	2022/3/28	YX

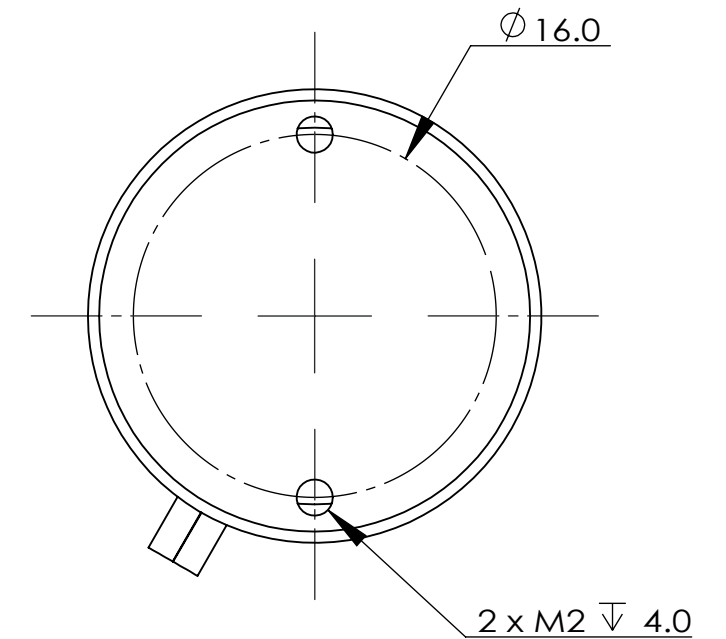
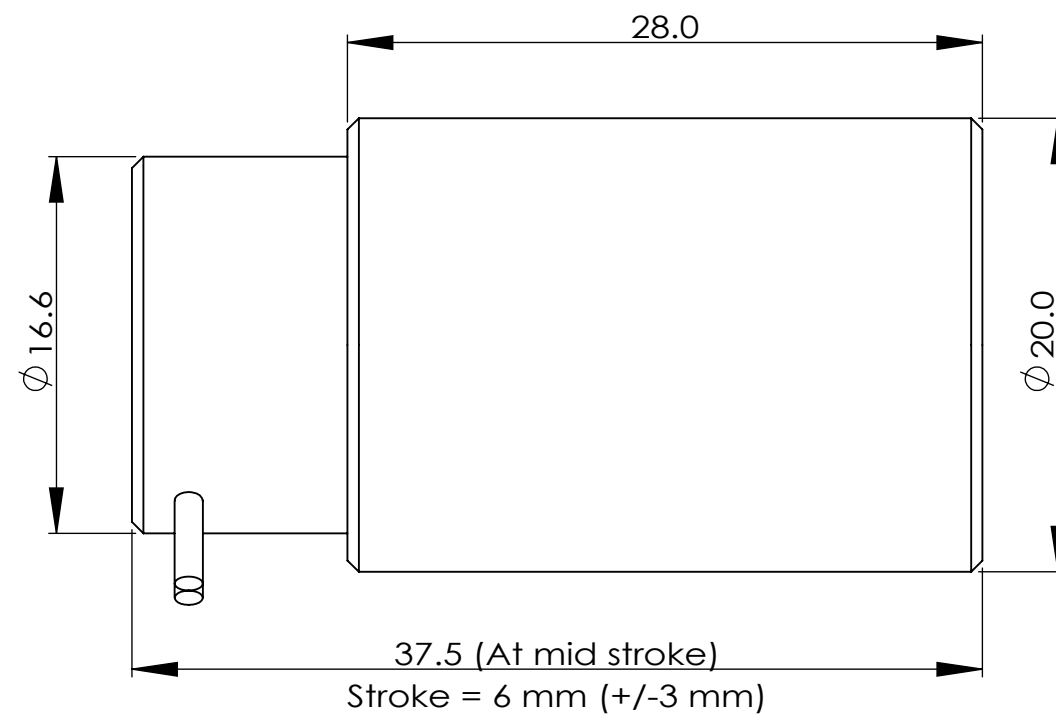
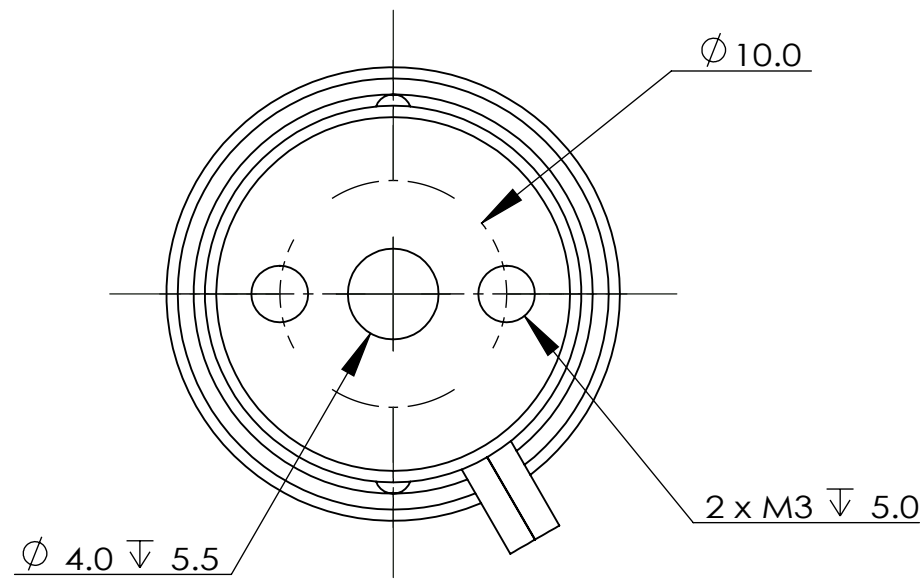
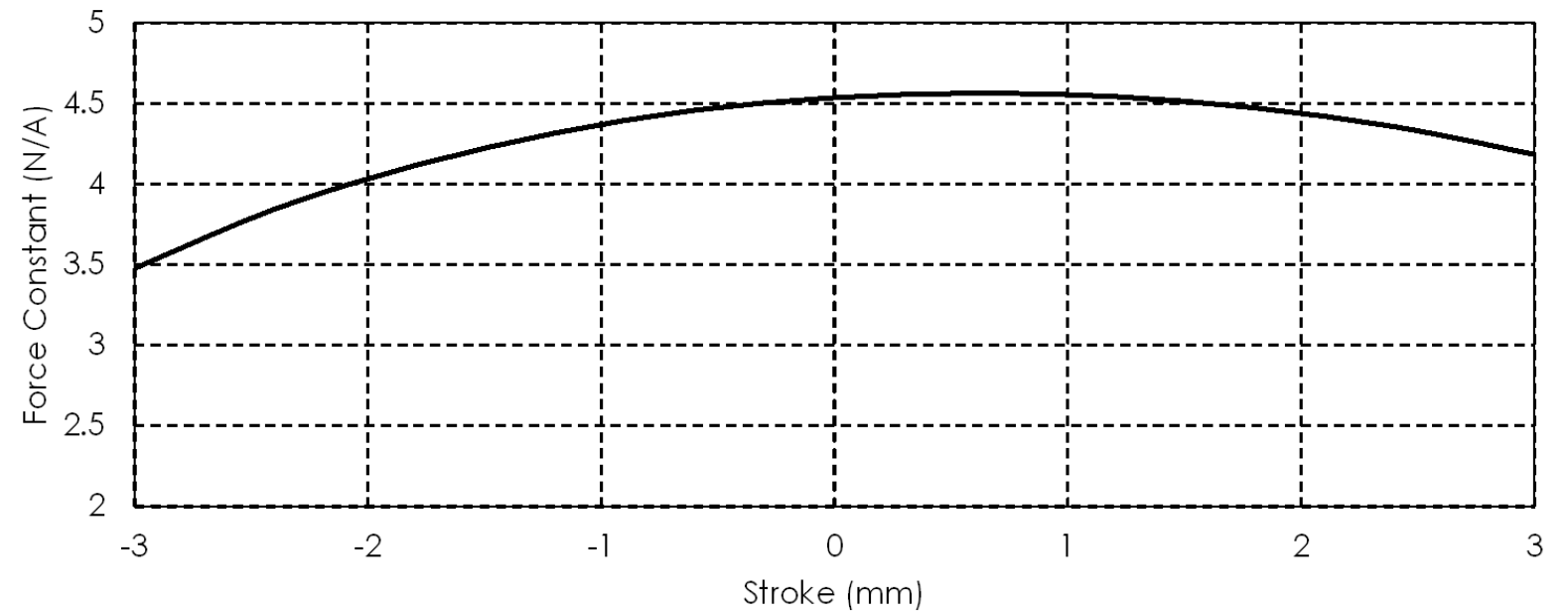

AKRIBIS SYSTEMS
CONFIDENTIAL:
THIS DOCUMENT AND
THE INFORMATION
CONTAINED IN IT ARE
CONFIDENTIAL, AND
CANNOT BE COPIED OR
DISCLOSED IN WHOLE
OR IN PART WITHOUT
WRITTEN CONSENT OF
AKRIBIS SYS PTE LTD

UNLESS OTHERWISE SPECIFIED,
ALL DIMENSIONS IN mm
REMOVE ALL SHARP EDGES

GENERAL
TOLERANCE
X ± 0.25mm
X.X ± 0.1mm
X.XX ± 0.05mm
X.XXX ± 0.025mm



Designed	WSM	2022/3/28
Drawn	WSM	2022/3/28
Checked	YH	2022/3/28
Approved	YX	2022/3/28
Material	NA	
Surface Treatment	NA	
Heat Treatment	NA	
Quantity	NA	



Akribis
Systems Pte Ltd
©2004. All rights reserved.

Model:	AVM20-HF-6_Customer Drawing
Title:	AVM20-HF-6_Customer Drawing
Dwg No:	AVM20-HF-6
Sheet:	1 OF1
Rev:	0