

Performance Parameters	Symbol	Unit	AVM150-HF-20
Stroke	S	mm	20.0
Continuous Force @100°C ^{[1][2]}	F _c	N	626.0
Peak Force ^[2]	F _{pk}	N	1882.5
Force Constant ±10% ^[2]	K _f	N/A	104.3
Back EMF Constant ±10% ^[2]	K _e	V/(m/s)	104.3
Motor Constant @25°C ^[2]	K _m	N/Sqrt(W)	61.3
Resistance @25°C ±10% ^[3]	R ₂₅	Ω	2.90
Inductance ±20% ^[4]	L	mH	2.10
Electrical Time Constant	T _e	ms	0.72
Continuous Current @100°C ^[1]	I _c	A	6.0
Peak Current	I _{pk}	A	18.0
Continuous Power Dissipation @100°C ^[1]	P _c	W	134.5
Max. Coil Temperature	t _{max}	°C	100
Thermal Dissipation Constant ^[1]	K _{th}	W/°C	1.794
Max. Voltage	U _{max}	Vdc	120
Coil Mass	m _{coil}	g	1500.0
Core Mass	m _{core}	g	13100.0
Running Clearance	L _{gap}	mm	0.75

[1] Measurement is taken at ambient temperature 25°C. Value depends on the thermal environment.
 [2] The values are at mid stroke.
 [3] Resistance is measured by DC current with 0.5 m lead wire.
 [4] Inductance is measured by current frequency of 1 kHz.
 The contents of datasheet are subject to change without prior notice.

REV	DESCRIPTION	BY	DATE	APPD
0	INITIAL RELEASE	SL	2021/10/26	YX

AVM150-HF-20

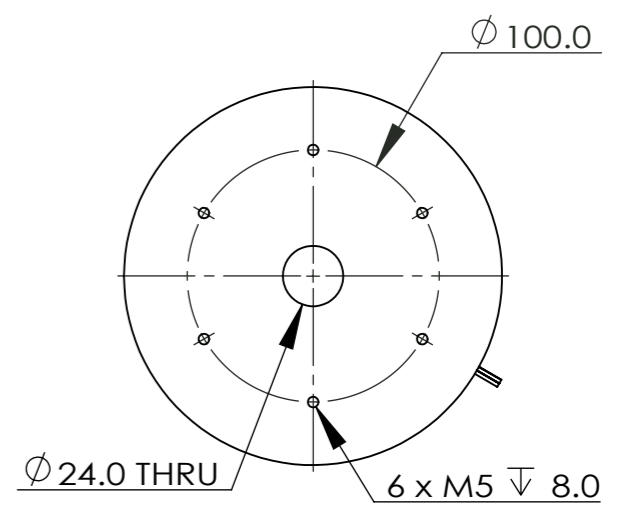
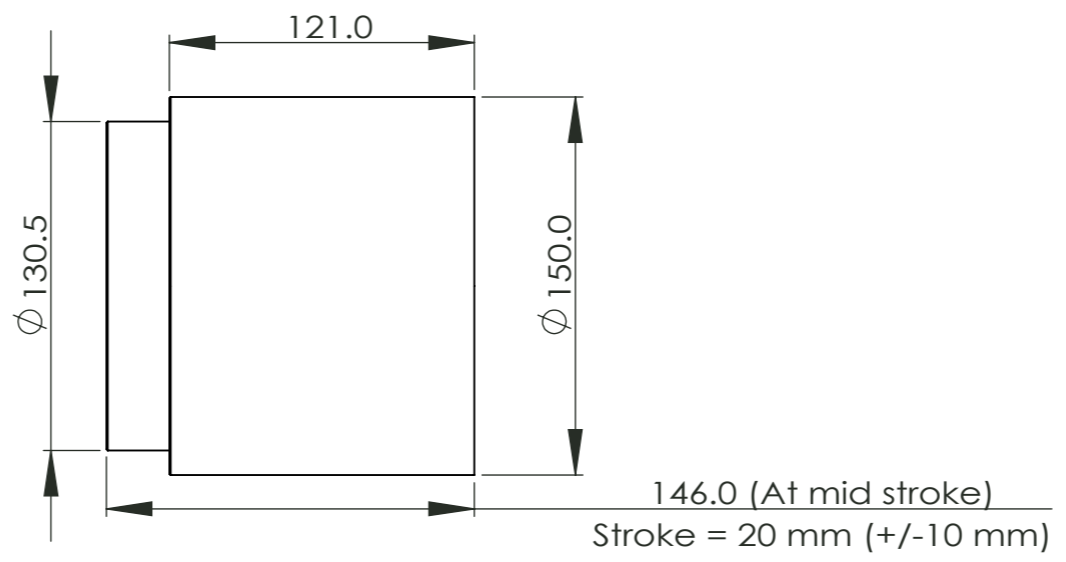
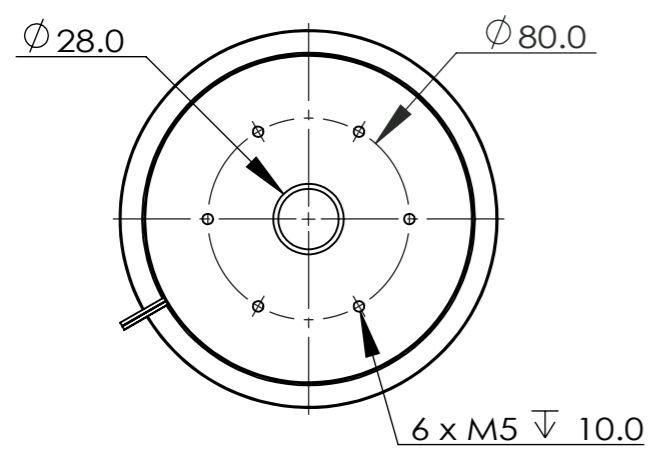
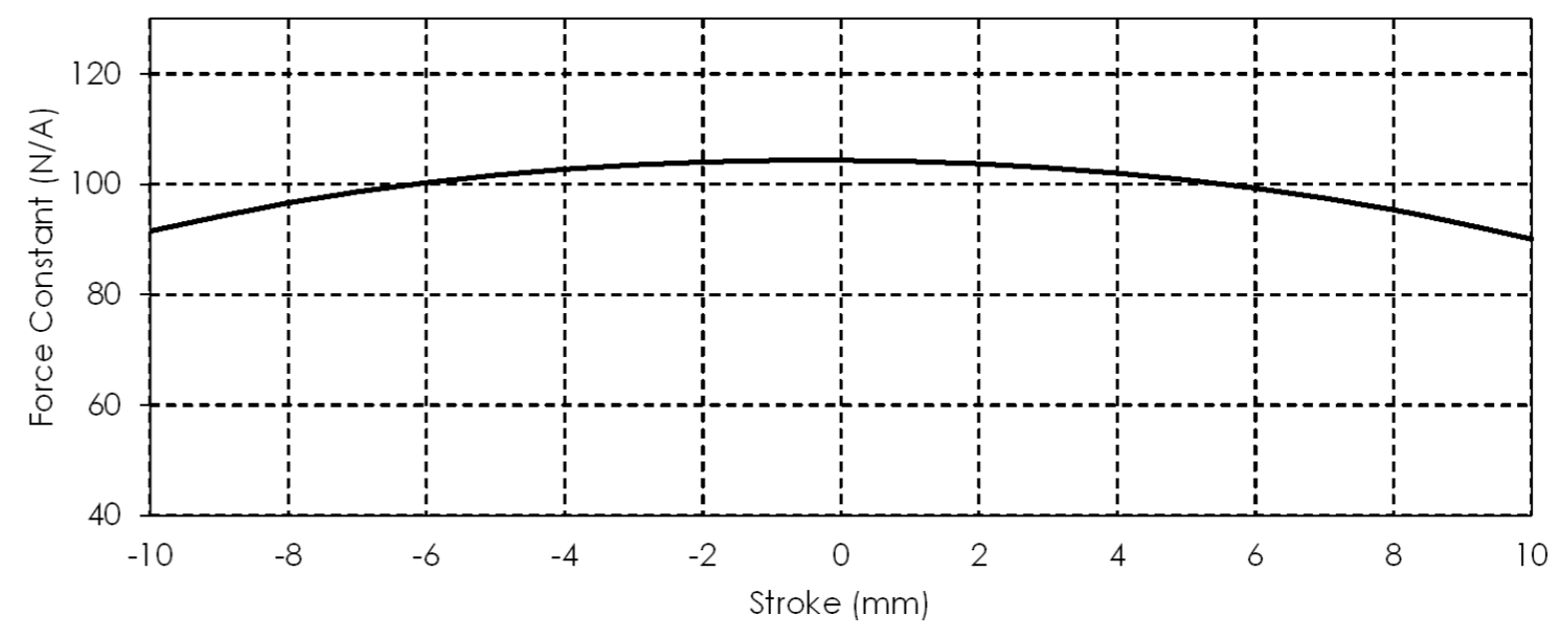

AKRIBIS SYSTEMS CONFIDENTIAL: THIS DOCUMENT AND THE INFORMATION CONTAINED IN IT ARE CONFIDENTIAL, AND CANNOT BE COPIED OR DISCLOSED IN WHOLE OR IN PART WITHOUT WRITTEN CONSENT OF AKRIBIS SYS PTE LTD	UNLESS OTHERWISE SPECIFIED, ALL DIMENSIONS IN mm	Designed	SL	2021/10/25	Akribis Systems Pte Ltd ©2004. All rights reserved.	
	REMOVE ALL SHARP EDGES	Drawn	SL	2021/10/25		
	GENERAL TOLERANCE X ± 0.25mm X.X ± 0.1mm X.XX ± 0.05mm X.XXX ± 0.025mm	3rd ANGLE PROJECTION	Checked	YH		2021/10/26
			Approved	YX		2021/10/26
			Material	NA		
			Surface Treatment	NA		
		Heat Treatment	NA		Model: AVM150-HF-20_Customer Drawing	
		Quantity	NA		Title: AVM150-HF-20_Customer Drawing	
					Dwg No: AVM150-HF-20	
					Sheet: 1 OF 1	
					Rev: 0	